

**GORBEL**  
A CLASS ABOVE

[www.gorbel.com](http://www.gorbel.com)



# CRANES

## PERFORMANCE JIB CRANES

- CAPACITIES:** 1/4 to 5 tons
- SPANS:** Up to 30'
- ROTATION:** Manual or Motorized
- STYLES:** Free Standing, Wall Mounted or Gantry



## WORK STATION JIB CRANES

### WORK STATION JIB CRANES

Work Station Jib Cranes are the ideal substitute for traditional, heavy I-Beam Jib Cranes. These jibs are designed to service circular areas and support tool balancers, air balancers, vacuum lifters and hoists. When column or wall mounted, they can handle up to a 200° rotation. When floor mounted, they can accommodate up to a 360° rotation. Capacities are available from 100 lbs. to 1000 lbs. with spans up to 16 ft.

### FEATURES:

- Tapered roller pivot bearings and trunnion rollers for ease of rotation.
- Enclosed track boom that virtually eliminates dirt and dust.
- High-strength, lightweight, low-headroom boom assemblies.
- Many of the smaller, lighter capacity jibs can be mounted on any normal 6" reinforced concrete floor (no foundation required; contact the factory for details).
- Enclosed track boom provides effortless trolley movement and virtually eliminates dust and dirt.



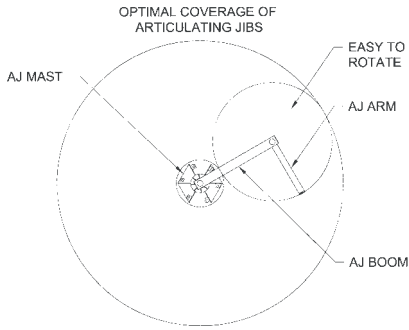

### ARTICULATING JIB CRANES

This versatile crane can move loads around corners, reach into machines or doorways, and swing under obstructions. This crane is also perfect in applications that require an operator to rotate the jib in close to its pivot point. Capacities from 150 lbs. to 2000 lbs. with spans up to 16 ft.

### AL100 WALL BRACKET WORK STATION JIB CRANES 200° ROTATION

The AL100 Wall Bracket Work Station Jib Crane utilizes Gorbel's patented lightweight, high-strength extruded aluminum enclosed track. This revolutionary track reduces the rotational dead weight of the boom by 56% to 68%, making the jib up to 40% easier to rotate than comparable I-beam jibs. The tie rod design minimizes deflection and is more precise when positioning loads than other jibs.

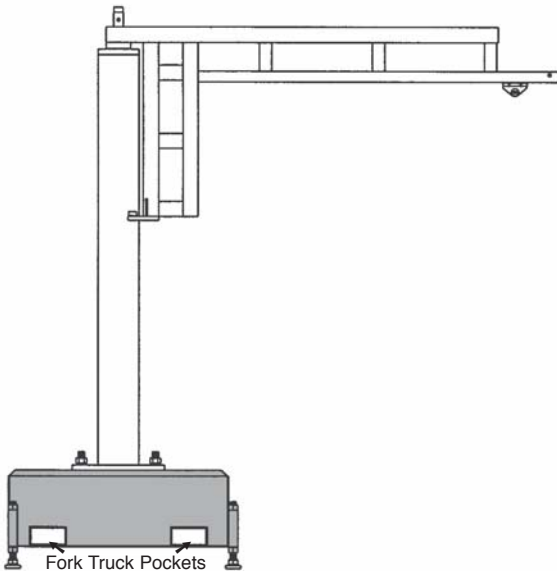

### PORTABLE BASES

The portable bases allow jibs to be picked up with a fork truck and moved anywhere in a facility. They are available in capacities up to 1000 lbs. and spans up to 16 ft.

## NINE REASONS WHY YOU SHOULD CHOOSE GORBEL CRANES

### 1 Industry's Best Warranty

- 5 years on Manual Cranes
- 2 years on Motorized Cranes

### 2 Industry's Best Delivery

5-Day Shipments are available for all manually operated cranes in this brochure. 2- or 3-Day service is also available (premium service).

### 3 Multiple Shipping Points

With multiple manufacturing facilities, we ship from the closest plant which lowers freight costs and reduces shipping damage.

### 4 "If it's late, we pay the freight"

When delivery is critical, you can depend on Gorbel. Upon request, we will guarantee your crane will be ready for shipment on the promised date or we will pay the freight

(see dealer for details).

### 5 Ease of Installation

All components are built and assembled with jigs and fixtures which ensure easy installation.

### 6 Ease of Operation

This helps reduce injuries and increase productivity.

### 7 Local Representation

Gorbel Jib and Gantry Cranes are sold and serviced by a nationwide network of material handling specialists that provide material handling solutions.

### 8 Versatility

Gorbel makes a complete line of jib cranes to meet the needs of the material handler.

### 9 Safety

All cranes are pre-engineered for powered hoist operation—with a factor of 15% of the jib capacity for the combined weight of the hoist and trolley and an additional factor of 25% of the jib capacity for the impact of powered hoists\*.

\*Note impact-ratings are designed to accommodate standard powered chain hoists with lift speeds up to 30 f.p.m. High-speed hoists, wire rope hoists, and magnet use may require an additional impact factor.



## MOTORIZED JIB CRANES

Motorized Jibs are available in the Free Standing, Wall Cantilever, Wall Bracket, and Mast Type Series. Retrofit Motorized kits for Free Standing Jibs are also available.

### WHY A GORBEL MOTORIZED JIB CRANE?

Gorbel Motorized Jibs are not mere adaptations. They are totally conceived as motorized products, with all the outstanding features of our standard jibs, plus these:

- Variable Frequency Drives (VFD) are standard on all Motorized Jib Cranes. The drive can be configured for single or multiple speeds.
- Precision drive assembly with field adjustable torque limiter for added drive protection.
- Worm gear reducer with oil bath lubrication for reliable operation, and low maintenance. Worm gear reducer includes overload safety clutch.
- Totally enclosed, fan cooled, 3 phase Class B, 40°C ambient continuous, "C" faced motor, 30 minute rated, is standard.
- Direct drive for all series of jib cranes allows for accurate and consistent positioning of loads. This modular drive design makes maintenance easy and reduces long term costs.
- Wall Cantilever and Mast Type masts are boxed for extra rigidity to withstand the forces of a Motorized Crane and provide more precise load control.

FS300DD

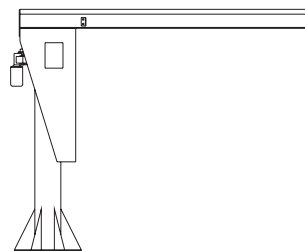

WB100MD

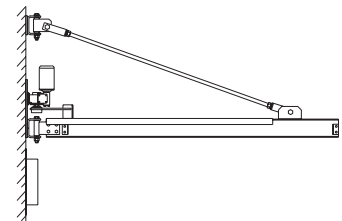

WC200MD

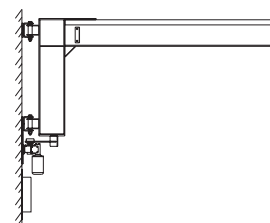

MT400MD

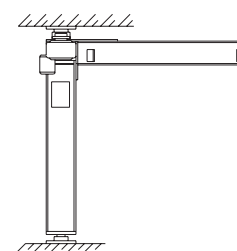

## RETROFIT EXISTING JIBS WITH MOTORIZED ROTATION

The Retrofit Traction Drive kit will fit all Free Standing Jibs with box-style head assemblies no matter who made your jib crane. The modular drive assembly bolts to the back of the box-style head assembly. The drive powers large, heavy-walled rollers. The drive roller is easily adjusted to ensure a constant driving force. This is a great way to upgrade an existing Free Standing Jib Crane with motorized power making the Retrofit Kit a great, cost-effective way to solve workers' compensation or safety problems. Retrofit Traction Drive kits are available for indoor applications up to 5 ton with spans to 20 feet.

This Retrofit Motorized FS300 Free Standing Jib Crane gives operators the control needed to quickly and precisely position loads.

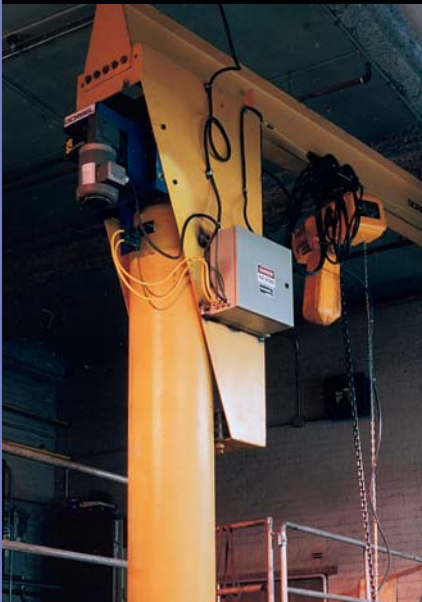

## SUPERIOR LOAD POSITIONING CONTROL PACKAGES

### FEATURES OF MOTORIZED CONTROL PACKAGE

- Variable Frequency Drive (VFD) is standard.

The Variable Frequency Drive can be used in one, two, or three speed applications.

- Variable Frequency Drive provides the ultimate in load control.

The VFD provides the ultimate in load control and positioning from the slowest possible creep speed up to maximum speed. The VFD is up to 25 times smoother than ballast resistor controls, does not produce extensive heat, and enables precise starting and stopping.

- Easily adjustable speed control.

Through a simple keypad on the VFD, the acceleration rate, deceleration rate and rotation speed can be adjusted to fit your application. This allows you to customize the performance of the Jib to your exact requirements.

- Designed for indoor and outdoor use.

When being used outdoors, the cranes are designed to operate in winds of 15 mph or less, based on a maximum load surface of 64 square feet. Consult the factory for applications exceeding these standards.

- Standard NEMA Rated Control Enclosure.

Gorbel's standard control enclosure meets the requirements for NEMA 3R, 12, 4, and 4X environments. Optional enclosures are available for other environments.

- Low maintenance costs.

The VFD eliminates the need for magnetic reversing contactors, reduces the number of wearable components in the panel, and reduces long-term maintenance costs.



The direct drive powers the rotation of the Free Standing Crane. A speed of 1/2 RPM is standard.

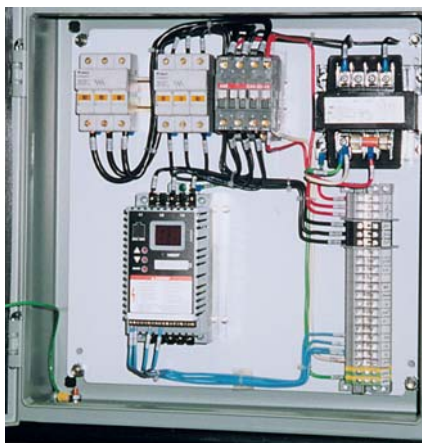

Variable Speed Controls provide the ultimate in jib crane rotation control from creep speed to maximum speed.



## MAXIMUM VERSATILITY AND PERFORMANCE

Gorbel's most versatile crane. Perfect for underneath large bridge cranes, in open areas where it can serve several work stations, in outdoor applications such as loading docks, or in machining and assembly operations where it can be overlapped with other jibs to provide staged operation.

## FREE STANDING JIB CRANES

### GORBEL'S ADVANTAGE

#### EASE OF OPERATION

- Allows operators to position loads precisely, effortlessly and efficiently.
- Precision tapered roller bearings in top pivot and trunnion assemblies provide smooth operation and long life.
- Full supporting triangular base plate gussets are used (in lieu of struts) to minimize crane deflection, thus making it easier to accurately position loads.

#### EASE OF INSTALLATION

- Independent head assembly, installed separately from the boom for easier installation.
- Recessed bearing assembly allows greatly reduced clearances needed for installation.
- Bolted head/boom connection which permits separate installation and provides maximum lift for the hoist, since it can be installed very close to the underside of the lower ceiling obstruction for greater headroom.
- Movable bolted trolley stops.
- In-head totally enclosed, bottom entry collector assembly allows the option of easily adding power to the hoist for 360° rotation at the time of or after purchase.

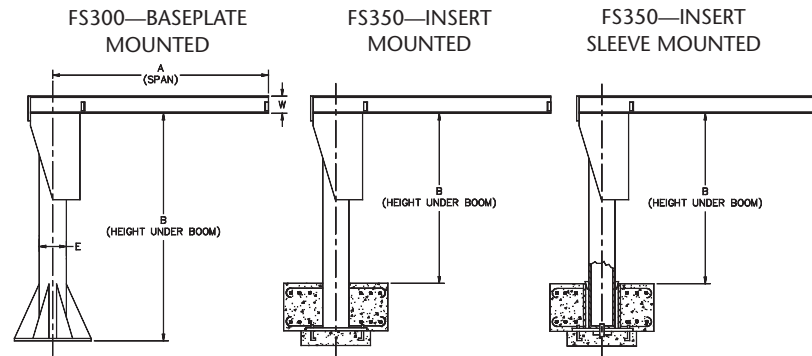
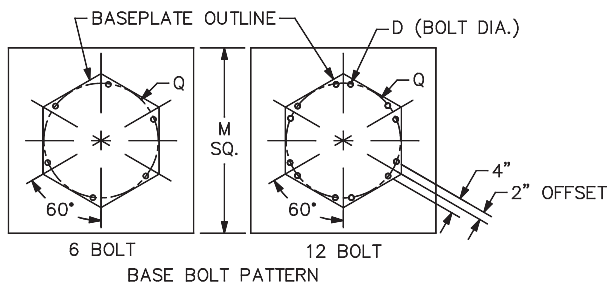

#### SAFETY

- Head retaining pin provides the resistance to accidental upward dislodgement of the head.
- Pre-engineered for use with powered hoists. A factor of 15% of the jib crane capacity is allowed for the hoist and trolley weight with an additional 25% of the capacity allowed for impact, thus, giving maximum capacity use of the jib.

#### POWER ROTATION

- Is optional (see pages 4 & 5 for details).

Mast Diameter E	8"	12"	14"	16"	18"	20"	24"	30"
Number of Anchor Bolts	6	6	6	12	12	12	12	12
Bolt Diameter (D)	1"	1.25"	1.25"	1.25"	1.25"	1.25"	1.25"	1.25"
Bolt Circle* (Q)	24"	24"	30"	36"	42"	48"	54"	60"

Note: For jib crane foundation requirements, overturning moment, axial load and anchor bolt pull out forces, consult your local Gorbel dealer.  
\*Note: Dimensions from corners of the hexagonal baseplate are 6" longer than the corresponding bolt circle.

# FS300 BASEPLATE MOUNTED

Capacity	Dim B	SPAN A						
		8'	10'	12'	14'	16'	18'	20'
1/4 TON	8'	FS300-8-6	FS300-8-6	FS300-8-6	FS300-12-8	FS300-12-8	FS300-12-10	FS300-12-10
	10'	FS300-8-6	FS300-8-6	FS300-8-6	FS300-12-8	FS300-12-8	FS300-12-10	FS300-12-10
	12'	FS300-8-6	FS300-8-6	FS300-12-6	FS300-12-8	FS300-12-8	FS300-12-10	FS300-12-10
	14'	FS300-8-6	FS300-8-6	FS300-12-6	FS300-12-8	FS300-12-8	FS300-12-10	FS300-14-10
	16'	FS300-8-6	FS300-8-6	FS300-12-6	FS300-12-8	FS300-12-8	FS300-12-10	FS300-14-10
	18'	FS300-8-6	FS300-12-6	FS300-12-6	FS300-12-8	FS300-14-8	FS300-14-10	FS300-14-10
	20'	FS300-8-6	FS300-12-6	FS300-12-6	FS300-14-8	FS300-14-8	FS300-14-10	FS300-16-10
1/2 TON	8'	FS300-8-6	FS300-8-6	FS300-12-7	FS300-12-8	FS300-12-10	FS300-12-10	FS300-12-12
	10'	FS300-8-6	FS300-8-6	FS300-12-7	FS300-12-8	FS300-12-10	FS300-12-10	FS300-14-12
	12'	FS300-8-6	FS300-12-6	FS300-12-7	FS300-12-12	FS300-12-12	FS300-14-16	FS300-14-16
	14'	FS300-8-6	FS300-12-6	FS300-12-10	FS300-12-12	FS300-12-12	FS300-14-16	FS300-14-16
	16'	FS300-8-6	FS300-12-6	FS300-12-10	FS300-12-12	FS300-14-12	FS300-14-16	FS300-16-16
	18'	FS300-8-6	FS300-12-6	FS300-12-10	FS300-14-12	FS300-14-12	FS300-16-16	FS300-16-16
	20'	FS300-8-6	FS300-12-6	FS300-14-10	FS300-14-12	FS300-14-12	FS300-16-16	FS300-16-16
1 TON	8'	FS300-12-7	FS300-12-8	FS300-12-10	FS300-14-12	FS300-14-12	FS300-14-16	FS300-14-16
	10'	FS300-12-7	FS300-12-8	FS300-12-10	FS300-14-12	FS300-14-12	FS300-14-16	FS300-14-16
	12'	FS300-12-7	FS300-12-8	FS300-14-10	FS300-14-12	FS300-16-12	FS300-16-16	FS300-16-16
	14'	FS300-12-7	FS300-12-8	FS300-14-10	FS300-14-12	FS300-16-12	FS300-18-16	FS300-18-16
	16'	FS300-12-7	FS300-12-8	FS300-14-10	FS300-16-12	FS300-18-12	FS300-18-16	FS300-18-16
	18'	FS300-12-7	FS300-14-8	FS300-16-10	FS300-16-12	FS300-18-12	FS300-18-16	FS300-18-16
	20'	FS300-12-7	FS300-14-8	FS300-16-10	FS300-18-12	FS300-18-12	FS300-20-16	FS300-20-16
2 TON	8'	FS300-14-10	FS300-14-12	FS300-16-12	FS300-16-16	FS300-16-18	FS300-18-18	FS300-18-18
	10'	FS300-14-10	FS300-14-12	FS300-16-12	FS300-16-16	FS300-16-18	FS300-18-18	FS300-18-18
	12'	FS300-14-10	FS300-14-12	FS300-16-12	FS300-16-16	FS300-16-18	FS300-18-18	FS300-18-18
	14'	FS300-14-10	FS300-14-12	FS300-16-12	FS300-16-16	FS300-18-18	FS300-18-18	FS300-20-18
	16'	FS300-14-10	FS300-14-12	FS300-16-12	FS300-18-16	FS300-18-18	FS300-18-18	FS300-24-18
	18'	FS300-14-10	FS300-16-12	FS300-18-12	FS300-18-16	FS300-20-18	FS300-20-18	FS300-24-18
	20'	FS300-14-10	FS300-16-12	FS300-18-12	FS300-18-16	FS300-20-18	FS300-20-18	FS300-24-18
3 TON	8'	FS300-16-12	FS300-16-16	FS300-18-16	FS300-18-18	FS300-20-18	FS300-20-21	FS300-24-24
	10'	FS300-16-12	FS300-16-16	FS300-18-16	FS300-18-18	FS300-20-18	FS300-20-21	FS300-24-24
	12'	FS300-16-12	FS300-16-16	FS300-18-16	FS300-18-18	FS300-20-18	FS300-20-21	FS300-24-24
	14'	FS300-16-12	FS300-16-16	FS300-18-16	FS300-18-18	FS300-20-18	FS300-20-21	FS300-24-24
	16'	FS300-16-12	FS300-16-16	FS300-18-16	FS300-18-18	FS300-20-18	FS300-24-21	FS300-24-24
	18'	FS300-16-12	FS300-16-16	FS300-18-16	FS300-20-18	FS300-24-18	FS300-24-21	FS300-24-24
	20'	FS300-16-12	FS300-16-16	FS300-20-16	FS300-20-18	FS300-24-18	FS300-24-21	FS300-24-24
5 TON	8'	FS300-18-16	FS300-20-18	FS300-24-18	FS300-24-21	FS300-24-24	FS300-30-24	FS300-30-24
	10'	FS300-18-16	FS300-20-18	FS300-24-18	FS300-24-21	FS300-24-24	FS300-30-24	FS300-30-24
	12'	FS300-18-16	FS300-20-18	FS300-24-18	FS300-24-21	FS300-24-24	FS300-30-24	FS300-30-24
	14'	FS300-18-16	FS300-20-18	FS300-24-18	FS300-24-21	FS300-24-24	FS300-30-24	FS300-30-24
	16'	FS300-18-16	FS300-20-18	FS300-24-18	FS300-24-21	FS300-24-24	FS300-30-24	FS300-30-24
	18'	FS300-18-16	FS300-20-18	FS300-24-18	FS300-24-21	FS300-24-24	FS300-30-24	FS300-30-24
	20'	FS300-18-16	FS300-20-18	FS300-24-18	FS300-24-21	FS300-24-24	FS300-30-24	FS300-30-24

**Model Number Explanation**

Example: 1/4 Ton FS300-8-6; 1/4 Ton = 500 pound capacity, FS300 = base plate mount style, 8 = mast diameter in inches (E), 6 = boom depth in inches (W). Use 'E' dimension on page 4 to determine base plate and anchor bolt dimensions.

**Other Models, Sizes and Capacities**

FS350 (insert mounted), FS350S (sleeve insert mounted), and other spans, heights, and capacities are available by contacting your local Gorbelt Dealer.

*Dimensions are subject to change without notice.*



## THE ECONOMICAL SOLUTION

The Wall Bracket (WB100) Jib is the most economical means of providing hoist coverage for individual use in bays, along walls or columns of plants, or as a supplement to an overhead crane or monorail system.

Two key requirements must be met before applying the Wall Bracket Series:

- 1) A structurally adequate wall or column to support the jib must exist.
- 2) Sufficient clearance above the boom throughout its arc to accommodate the tie rod suspension must exist.

## GORBEL'S ADVANTAGE

### EASE OF MOVEMENT

- Low dead weight of the boom combined with bronze bushings and oil-impregnated bronze thrust washers provide for easy rotation and superior load positioning.

### SAFETY

- Formed bracket fittings provide for greater reliability. No welds in tension, all bolts are in double shear.
- Pre-engineered for use with powered hoists. A factor of 15% of the jib crane capacity is allowed for the hoist and trolley weight with an additional 25% of the capacity allowed for impact, thus giving maximum capacity use of the jib.

### EASE OF INSTALLATION

- Single tie rod, right hand threaded, at both ends for easy boom adjustment and installation.
- All connections bolted, including movable bolted trolley stops.
- Grease fittings are provided for easy field lubrication.

### 200° POWER ROTATION

- Is optional (see pages 4 & 5 for details).



## WALL BRACKET JIB CRANES

WB100-WALL BRACKET

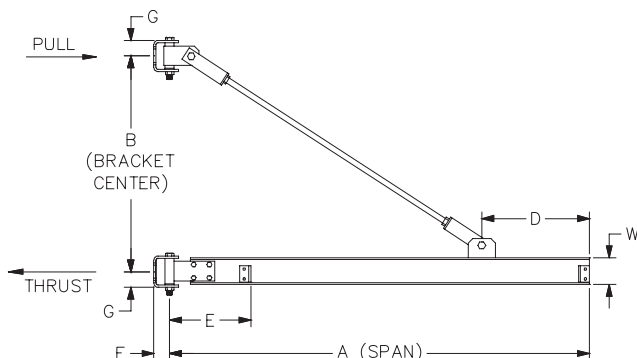

The Thrust & Pull diagram above details the thrust and pull forces that the jib applies to the supporting structure when a load is lifted. It is essential that a structurally adequate wall or column exists. Refer to the Thrust & Pull chart opposite this page for exact forces.

Fitting kits are available for fabrication of cranes locally.

TOP BRACKET FITTING



BEAM BRACKET FITTING



BOTTOM BRACKET FITTING



Fitting kits are available for fabrication of cranes locally.



# WB100 WALL BRACKET

Capacity	Span A	Model Number	B	D	E	F	G	W	Tie Rod Diameter	Thrust & Pull
1/2 TON	8'	WB100-G1-8-6	2' 9"	1' 3"	13 1/2"	3 1/2"	3 1/2"	6"	1"	3709#
	10'	WB100-G1-10-6	3' 0"	1' 6"	13 1/2"	3 1/2"	3 1/2"	6"	1"	4408#
	12'	WB100-G1-12-6	3' 9"	1' 9"	13 1/2"	3 1/2"	3 1/2"	6"	1"	4347#
	14'	WB100-G1-14-6	4' 6"	2' 0"	13 1/2"	3 1/2"	3 1/2"	6"	1"	4317#
	16'	WB100-G1-16-6	5' 6"	2' 0"	13 1/2"	3 1/2"	3 1/2"	6"	1"	4109#
	18'	WB100-G1-18-7	6' 0"	2' 0"	13 1/2"	3 1/2"	3 1/2"	7"	1"	4380#
	20'	WB100-G1-20-8	6' 6"	2' 3"	13 1/2"	3 1/2"	3 1/2"	8"	1"	4658#
	24'	WB100-G1-24-8c6	7' 6"	2' 6"	13 1/2"	3 1/2"	3 1/2"	8"	1"	5350#
30'	WB100-G1-30-12c8	10' 0"	3' 6"	13 1/2"	3 1/2"	3 1/2"	12"	1"	6009#	
1 TON	8'	WB100-G1-8-6	2' 9"	1' 3"	13 1/2"	3 1/2"	3 1/2"	6"	1"	7273#
	10'	WB100-G1-10-6	3' 0"	1' 6"	13 1/2"	3 1/2"	3 1/2"	6"	1"	8608#
	12'	WB100-G1-12-6	3' 9"	1' 9"	13 1/2"	3 1/2"	3 1/2"	6"	1"	8453#
	14'	WB100-G1-14-7	4' 6"	2' 0"	13 1/2"	3 1/2"	3 1/2"	7"	1"	8422#
	16'	WB100-G1-16-7	5' 6"	2' 3"	13 1/2"	3 1/2"	3 1/2"	7"	1"	7992#
	18'	WB100-G1-18-8	6' 0"	2' 6"	13 1/2"	3 1/2"	3 1/2"	8"	1"	8430#
	20'	WB100-G1-20-10	6' 6"	2' 6"	13 1/2"	3 1/2"	3 1/2"	10"	1"	8966#
	24'	WB100-G1-24-10c8	7' 6"	2' 9"	13 1/2"	3 1/2"	3 1/2"	10"	1"	9877#
30'	WB100-G1-30-12c8	10' 0"	3' 6"	13 1/2"	3 1/2"	3 1/2"	12"	1"	10069#	
2 TON	8'	WB100-G2-8-8	2' 9"	1' 3"	13 1/2"	4"	4 1/8"	8"	1 1/2"	14469#
	10'	WB100-G2-10-8	3' 0"	1' 6"	13 1/2"	4"	4 1/8"	8"	1 1/2"	17107#
	12'	WB100-G2-812-8	3' 9"	1' 9"	13 1/2"	4"	4 1/8"	8"	1 1/2"	16780#
	14'	WB100-G2-14-8	4' 6"	2' 0"	13 1/2"	4"	4 1/8"	8"	1 1/2"	16578#
	16'	WB100-G2-16-10	5' 6"	2' 3"	13 1/2"	4"	4 1/8"	10"	1 1/2"	15864#
	18'	WB100-G2-18-10	6' 0"	2' 3"	13 1/2"	4"	4 1/8"	10"	1 1/2"	16552#
	20'	WB100-G2-20-12	6' 6"	2' 6"	13 1/2"	4"	4 1/8"	12"	1 1/2"	17348#
	24'	WB100-G2-24-12c8	7' 6"	3' 0"	13 1/2"	4"	4 1/8"	12"	1 1/2"	18836#
30'	WB100-G2-30-12c8	10' 0"	3' 0"	13 1/2"	4"	4 1/8"	12"	1 1/2"	18189#	
3 TON	8'	WB100-G3-8-8	2' 9"	1' 3"	14"	4"	4 5/8"	8"	1 1/2"	21596#
	10'	WB100-G3-10-8	3' 3"	1' 6"	14"	4"	4 5/8"	8"	1 1/2"	23545#
	12'	WB100-G3-12-10	4' 0"	1' 9"	14"	4"	4 5/8"	10"	1 1/2"	23557#
	14'	WB100-G3-14-10	4' 9"	2' 0"	14"	4"	4 5/8"	10"	1 1/2"	23514#
	16'	WB100-G3-16-10	5' 6"	2' 3"	14"	4"	4 5/8"	10"	1 1/2"	23500#
	18'	WB100-G3-18-12	6' 3"	2' 3"	14"	4"	4 5/8"	12"	1 1/2"	23672#
	20'	WB100-G3-20-12c8	7' 0"	2' 6"	14"	4"	4 5/8"	12"	1 1/2"	24037#
	24'	WB100-G3-24-12c8	8' 6"	3' 0"	14"	4"	4 5/8"	12"	1 1/2"	24197#
30'	WB100-G3-30-12c8	11' 0"	3' 0"	14"	4"	4 5/8"	12"	1 1/2"	23917#	
5 TON	8'	WB100-G5-8-12	3' 0"	1' 6"	15 1/4"	6"	7"	12"	2"	33006#
	10'	WB100-G5-10-12	3' 3"	1' 6"	15 1/4"	6"	7"	12"	2"	39258#
	12'	WB100-G5-12-12	4' 0"	1' 9"	15 1/4"	6"	7"	12"	2"	39072#
	14'	WB100-G5-14-12	4' 9"	2' 0"	15 1/4"	6"	7"	12"	2"	38972#
	16'	WB100-G5-16-16	5' 6"	2' 6"	15 1/4"	6"	7"	16"	2"	39229#
	18'	WB100-G5-18-16	6' 3"	3' 0"	15 1/4"	6"	7"	16"	2"	39246#
	20'	WB100-G5-20-16c12	7' 0"	3' 6"	15 1/4"	6"	7"	16"	2"	39877#
	24'	WB100-G5-24-16c12	8' 6"	3' 6"	15 1/4"	6"	7"	16"	2"	40708#
30'	WB100-G5-30-16c12	11' 0"	3' 6"	15 1/4"	6"	7"	16"	2"	39597#	

**Model Number Explanation:**

Example: 3 Ton WB100-G3-20-12c8: 3 Ton = 6,000 pound capacity, WB100 = wall bracket style, 20 = span (A), 12 = boom depth in inches (W), c8 = 8" cap channel welded to top of boom.

**Other Sizes & Capacities**

Other spans and capacities are available by contacting your local Gorbels Dealer.

Dimensions are subject to change without notice.



## WALL CANTILEVER JIB CRANES

### FOR MAXIMUM LIFT:

The Wall Cantilever (WC200) provides hoist coverage and 200° rotation for individual use in bays, along walls or columns of plants, or as a supplement to an overhead crane or monorail system. This jib has the advantage of providing maximum lift for the hoist, since it can be installed very close to the underside of the lowest ceiling obstruction.

Two key requirements must be met before applying the Wall Cantilever Series:

- 1) A structurally adequate wall or column to support the jib must exist.
- 2) Sufficient clearance above the boom throughout its arc must exist.

WC200—WALL CANTILEVER

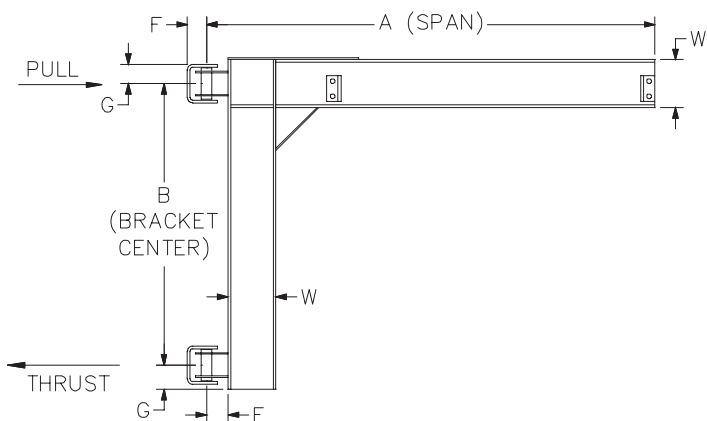

The diagram above details the thrust and pull forces that the jib crane applies to the supporting structure when a load is lifted. It is essential that a structurally adequate wall or column exists to support the jib crane. Refer to the Thrust & Pull chart opposite this page for exact forces.

## GORBEL'S ADVANTAGE

### EASE OF MOVEMENT

- The fittings containing bronze bushings and oil-impregnated bronze thrust washers which provide for easy rotation and superior load positioning.

### SAFETY

- Fabricated steel fittings provide excellent torsional rigidity.
- Pre-engineered for use with powered hoists. A factor of 15% of the jib crane capacity is allowed for the hoist and trolley weight with an additional 25% of the capacity allowed for impact, thus giving maximum capacity use of the jib.

### EASE OF INSTALLATION

- When the bracket center dimension is 6'0" or less, the mast/boom connection is welded. This provides the most economical means of installation.
- When the bracket center is greater than 6'0", a bolted mast/boom connection is used, which enables the larger cranes to be shipped disassembled for ease of handling during shipping and installation.
- Grease fittings are provided for easy field lubrication.

### 200° POWER ROTATION

- Is optional (see pages 4 & 5 details).

TOP AND BOTTOM BRACKET FITTINGS

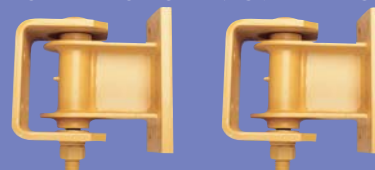

B1, B2, and B3 fitting kits are available for fabrication of cranes locally.

# WC200 WALL CANTILEVER

Capacity	A Span	Model Number	B	E	F	G	W	Thrust and Pull
1/4 TON	8'	WC200-B1-8-6	3' 0"	5"	3 1/2"	6"	6"	1767#
	10'	WC200-B1-10-6	3' 0"	5"	3 1/2"	6"	6"	2308#
	12'	WC200-B1-12-6	3' 0"	5"	3 1/2"	6"	6"	2867#
	14'	WC200-B1-14-7	3' 0"	5"	3 1/2"	6"	7"	3533#
	16'	WC200-B1-16-8	3' 0"	5"	3 1/2"	6"	8"	4285#
	18'	WC200-B1-18-8	4' 0"	5"	3 1/2"	6"	8"	3720#
	20'	WC200-B1-20-10	4' 0"	5"	3 1/2"	6"	10"	4595#
1/2 TON	8'	WC200-B1-8-7	3' 0"	5"	3 1/2"	6"	7"	3430#
	10'	WC200-B1-10-7	3' 0"	5"	3 1/2"	6"	7"	4455#
	12'	WC200-B1-12-7	3' 0"	5"	3 1/2"	6"	7"	5501#
	14'	WC200-B1-14-8	4' 0"	5"	3 1/2"	6"	8"	5001#
	16'	WC200-B1-16-10	4' 0"	5"	3 1/2"	6"	10"	6063#
	18'	WC200-B1-18-10	4' 0"	5"	3 1/2"	6"	10"	6979#
	20'	WC200-B1-20-12	6' 0"	5"	3 1/2"	6"	12"	5493#
1 Ton	8'	WC200-B1-8-8	4' 0"	5"	3 1/2"	6"	8"	5047#
	10'	WC200-B1-10-10	5' 0"	5"	3 1/2"	6"	10"	5294#
	12'	WC200-B1-12-10	5' 0"	5"	3 1/2"	6"	10"	6526#
	14'	WC200-B1-14-10	5' 0"	5"	3 1/2"	6"	10"	7778#
	16'	WC200-B1-16-12	6' 0"	5"	3 1/2"	6"	12"	7678#
	18'	WC200-B1-18-16	6' 0"	5"	3 1/2"	6"	16"	9148#
	20'	WC200-B1-20-16	6' 0"	5"	3 1/2"	6"	16"	10367#
2 TON	8'	WC200-B2-8-12	4' 0"	5"	4"	6"	12"	10054#
	10'	WC200-B2-10-12	4' 0"	5"	4"	6"	12"	12998#
	12'	WC200-B2-12-16	4' 6"	5"	4"	6"	16"	14409#
	14'	WC200-B2-14-16	5' 0"	5"	4"	6"	16"	15442#
	16'	WC200-B2-16-18	6' 0"	5"	4"	6"	18"	15067#
	18'	WC200-B2-18-18	6' 6"	5"	4"	6"	18"	15892#
	20'	WC200-B2-20-20	7' 6"	5"	4"	6"	21"	15840#
3 TON	8'	WC200-B3-8-16	4' 0"	5"	4"	6"	16"	15060#
	10'	WC200-B3-10-16	4' 6"	5"	4"	6"	16"	17300#
	12'	WC200-B3-12-16	5' 6"	5"	4"	6"	16"	17389#
	14'	WC200-B3-14-18	6' 0"	5"	4"	6"	18"	19017#
	16'	WC200-B3-16-18	7' 6"	5"	4"	6"	18"	17653#
	18'	WC200-B3-18-20	8' 6"	5"	4"	6"	21"	17982#
	20'	WC200-B3-20-24	9' 6"	5"	4"	6"	21"	18105#
5 TON	8'	WC200-B5-8-18	6' 6"	7"	6"	9"	18"	15323#
	10'	WC200-B5-10-18	6' 6"	7"	6"	9"	18"	19770#
	12'	WC200-B5-12-20	6' 6"	7"	6"	9"	21"	24379#
	14'	WC200-B5-14-20	7' 6"	7"	6"	9"	21"	25077#
	16'	WC200-B5-16-24	9' 6"	7"	6"	9"	21"	22941#
	18'	WC200-B5-18-24	9' 6"	7"	6"	9"	24"	26485#
	20'	WC200-B5-20-24	9' 6"	7"	6"	9"	24"	29769#

**Model Number Explanation:**

Example : 1 Ton WC200-B1-12-10; 1 Ton = 2,000 pound capacity, WC200 = Wall Cantilever style, 12 = span (A), 10 = boom depth in inches (W).

**Other Sizes and Capacities**

Other spans and capacities are available by contacting your local Gorbels Dealer.

*Dimensions are subject to change without notice.*





## THE ECONOMICAL 360° SOLUTION

The MT Series Crane is floor supported, top stabilized, and is capable of 360° rotation via a top and bottom bearing assembly.

Three key requirements must be met before deciding on a Mast Type Jib Crane:

1. An adequate structural support to stabilize the crane at the top of the mast must exist. If the jib is installed underneath an overhead crane runway or building truss, then the deflection of the supporting member may not exceed 1/2 inch.
2. Clearance overhead for the pivot assembly must exist.
3. Clearance overhead for the boom to rotate must exist.

## AVAILABLE IN TWO STYLES

- 1) MT400 FULL CANTILEVER—provides for maximum amount of lift where full use of available headroom is desired.
- 2) MT450 DROP CANTILEVER—jib boom can be placed at a specific height to clear overhead obstructions.

## MAST TYPE JIB CRANES

MT400—FULL CANTILEVER

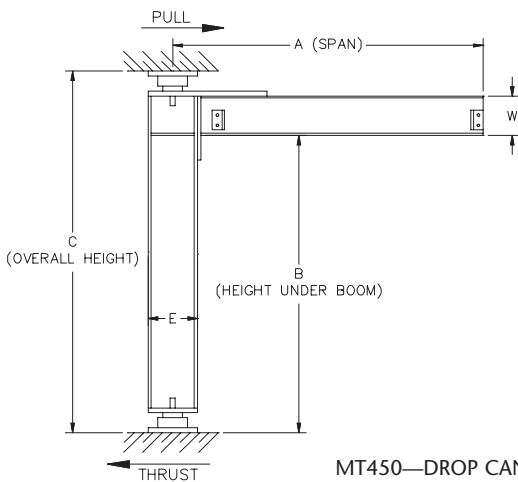

MT450—DROP CANTILEVER

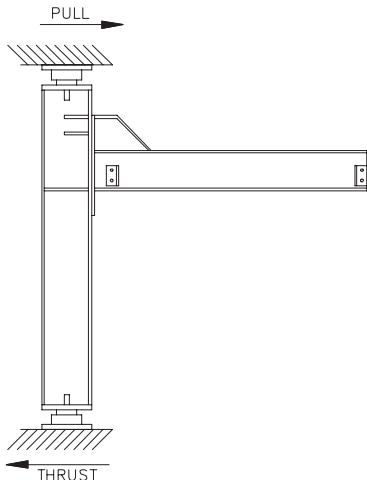

The diagram above details the thrust and pull forces that the jib crane applies to the supporting structure when a load is lifted. It is essential that a structurally adequate wall or column exists to support the jib crane. Contact your local Gorbel Dealer for specific thrust and pull forces.

## GORBEL'S ADVANTAGE

### ECONOMICAL

- Simple, efficient design that usually requires no special foundation makes the Mast Type Cranes the most cost effective of the 360° rotation jib styles.

### EXERTS LESS FORCE ON BUILDING STRUCTURE

- Exerts the least amount of force of any Gorbel jib on its supporting structure.

### SAFETY

- Utilizes a self-aligning radial bushing at the top which cannot be displaced, and an identical self-aligning radial bushing at the bottom which, used in combination with an oil-impregnated bronze thrust washer, provides ease of movement.
- Pre-Engineered for use with powered hoists. A factor of 15% of the jib crane capacity is allowed for the hoist and trolley weight with an additional 25% of the capacity allowed for impact, thus giving maximum capacity use of the jib.

### PRODUCTIVE

- Allows full utilization of the working area with 360° rotation.

### MAXIMUM TROLLEY TRAVEL

- Mast/beam connections eliminate the need for tie rods or knee braces found on competitive designs, thus permitting maximum trolley travel.

### POWER ROTATION

- Is optional (see pages 4 & 5 for details).

# MT400 MAST TYPE CRANES

		SPAN A						
Cap.	Dim C	8'	10'	12'	14'	16'	18'	20'
1/4 TON	10'	MT400-8-6-15	MT400-8-6-15	MT400-8-7-15	MT400-8-8-15	MT400-8-8-15	MT400-10-10-15	MT400-10-10-15
	12'	MT400-8-6-15	MT400-8-6-15	MT400-8-7-15	MT400-8-8-15	MT400-8-8-15	MT400-10-10-15	MT400-10-10-15
	14'	MT400-8-6-15	MT400-8-6-15	MT400-8-7-15	MT400-8-8-15	MT400-10-8-15	MT400-10-10-15	MT400-10-10-15
	16'	MT400-8-6-15	MT400-8-6-15	MT400-8-7-15	MT400-8-8-15	MT400-10-8-15	MT400-10-10-15	MT400-10-10-15
	18'	MT400-8-6-15	MT400-8-6-15	MT400-8-7-15	MT400-8-8-15	MT400-10-8-15	MT400-10-10-15	MT400-10-10-15
	20'	MT400-8-6-15	MT400-8-6-15	MT400-8-7-15	MT400-10-8-15	MT400-10-8-15	MT400-10-10-15	MT400-14-10-15
1/2 TON	10'	MT400-8-6-15	MT400-10-7-15	MT400-10-8-15	MT400-14-10-15	MT400-14-10-15	MT400-14-12-15	MT400-14-12-15
	12'	MT400-8-6-15	MT400-10-7-15	MT400-10-8-15	MT400-14-10-15	MT400-14-10-15	MT400-14-12-15	MT400-14-12-15
	14'	MT400-8-6-15	MT400-10-7-15	MT400-10-8-15	MT400-14-10-15	MT400-14-10-15	MT400-14-12-15	MT400-14-12-15
	16'	MT400-8-6-15	MT400-10-7-15	MT400-10-8-15	MT400-14-10-15	MT400-14-10-15	MT400-14-12-15	MT400-14-12-15
	18'	MT400-8-6-15	MT400-10-7-15	MT400-10-8-15	MT400-14-10-15	MT400-14-10-15	MT400-14-12-15	MT400-14-12-15
	20'	MT400-10-6-15	MT400-10-7-15	MT400-10-8-15	MT400-14-10-15	MT400-14-10-15	MT400-14-12-15	MT400-16-12-15
1 TON	10'	MT400-10-8-15	MT400-14-10-15	MT400-14-10-15	MT400-14-12-15	MT400-14-12-15	MT400-16-16-20	MT400-16-16-20
	12'	MT400-10-8-15	MT400-14-10-15	MT400-14-10-15	MT400-14-12-15	MT400-14-12-15	MT400-16-16-15	MT400-16-16-20
	14'	MT400-10-8-15	MT400-14-10-15	MT400-14-10-15	MT400-14-12-15	MT400-14-12-15	MT400-16-16-15	MT400-16-16-15
	16'	MT400-10-8-15	MT400-14-10-15	MT400-14-10-15	MT400-14-12-15	MT400-16-12-15	MT400-16-16-15	MT400-18-16-15
	18'	MT400-14-8-15	MT400-14-10-15	MT400-14-10-15	MT400-16-12-15	MT400-16-12-15	MT400-18-16-15	MT400-18-16-15
	20'	MT400-14-8-15	MT400-14-10-15	MT400-14-10-15	MT400-16-12-15	MT400-16-12-15	MT400-18-16-15	MT400-18-16-15
2 TON	10'	MT400-14-10-15	MT400-14-12-20	MT400-16-16-20	MT400-16-16-20	MT400-18-18-20	MT400-18-18-25	MT400-21-21-25
	12'	MT400-14-10-15	MT400-14-12-20	MT400-16-16-20	MT400-16-16-20	MT400-18-18-20	MT400-18-18-20	MT400-21-21-20
	14'	MT400-14-10-15	MT400-16-12-15	MT400-16-16-20	MT400-18-16-20	MT400-18-18-20	MT400-18-18-20	MT400-21-21-20
	16'	MT400-14-10-15	MT400-16-12-15	MT400-18-16-15	MT400-18-16-20	MT400-18-18-20	MT400-18-18-20	MT400-21-21-20
	18'	MT400-16-10-15	MT400-16-12-15	MT400-18-16-15	MT400-18-16-15	MT400-18-18-20	MT400-21-18-20	MT400-21-21-20
	20'	MT400-16-10-15	MT400-18-12-15	MT400-18-16-15	MT400-18-16-15	MT400-18-18-15	MT400-21-18-20	MT400-21-21-20
3 TON	10'	MT400-16-12-20	MT400-16-16-20	MT400-18-16-20	MT400-18-18-25	MT400-21-20-25	MT400-21-21-25	MT400-21-24-25
	12'	MT400-16-12-20	MT400-16-16-20	MT400-18-16-20	MT400-18-18-25	MT400-21-20-25	MT400-21-21-25	MT400-21-24-25
	14'	MT400-16-12-20	MT400-18-16-20	MT400-18-16-20	MT400-18-18-20	MT400-21-20-25	MT400-21-21-25	MT400-21-24-25
	16'	MT400-18-12-15	MT400-18-16-20	MT400-18-16-20	MT400-18-18-20	MT400-21-20-20	MT400-21-21-25	MT400-24-24-25
	18'	MT400-18-12-15	MT400-18-16-15	MT400-18-16-20	MT400-21-18-20	MT400-21-20-20	MT400-24-21-20	MT400-24-24-25
	20'	MT400-18-12-15	MT400-18-16-15	MT400-18-16-20	MT400-21-18-20	MT400-21-20-20	MT400-24-21-20	MT400-24-24-25
5 TON	10'	MT400-18-18-25	MT400-18-18-25	MT400-21-21-25	MT400-21-21-25	MT400-24-24-25	MT400-24-24-25	MT400-24-24-25
	12'	MT400-18-18-25	MT400-18-18-25	MT400-21-21-25	MT400-21-21-25	MT400-24-24-25	MT400-24-24-25	MT400-24-24-25
	14'	MT400-18-18-20	MT400-18-18-25	MT400-21-21-25	MT400-21-21-25	MT400-24-24-25	MT400-24-24-25	MT400-27-24-25
	16'	MT400-18-18-20	MT400-21-18-20	MT400-21-21-25	MT400-24-21-25	MT400-24-24-25	MT400-27-24-25	MT400-27-24-25
	18'	MT400-18-18-20	MT400-21-18-20	MT400-24-21-20	MT400-24-21-25	MT400-27-24-25	MT400-27-24-25	MT400-27-24-25
	20'	MT400-21-18-20	MT400-21-18-20	MT400-24-21-20	MT400-24-21-25	MT400-27-24-25	MT400-27-24-25	MT400-27-24-25

**Model Number Explanation**

Example: 1/2 Ton MT400-8-6-15; 1/2 Ton =1000 pound capacity, MT400 = full cantilever style, 8 = mast wide flange depth in inches (E), 6 = boom depth in inches (W), 15 = mast pivot pin diameter (1.5").

**Other Models, Sizes and Capacities**

MT450 (drop cantilever), and other spans, heights, and capacities are available by contacting your local Gorbel Dealer.

*Dimensions are subject to change without notice.*

# FIXED HEIGHT STEEL GANTRY CRANES

CAPACITY	A SPAN	MODEL NUMBER	B HUB	C OAH	D CLEAR SPAN	W I-BEAM DEPTH
1 TON	8'	FG-1-10-8	10'	10' 6"	6' 11-1/4"	6"
		FG-1-12-8	12'	12' 6"	6' 11-1/4"	6"
		FG-1-15-8	15'	15' 6"	6' 10-1/4"	6"
	10'	FG-1-10-10	10'	10' 6"	8' 11-1/4"	6"
		FG-1-12-10	12'	12' 6"	8' 11-1/4"	6"
		FG-1-15-10	15'	15' 6"	8' 10-1/4"	6"
	12'	FG-1-10-12	10'	10' 6"	10' 11-1/4"	6"
		FG-1-12-12	12'	12' 6"	10' 11-1/4"	6"
		FG-1-15-12	15'	15' 6"	10' 10-1/4"	6"
	15'	FG-1-10-15	10'	10' 7"	13' 11-1/4"	7"
		FG-1-12-15	12'	12' 7"	13' 11-1/4"	7"
		FG-1-15-15	15'	15' 7"	13' 10-1/4"	7"
	20'	FG-1-10-20	10'	10' 10"	18' 11-1/4"	10"
		FG-1-12-20	12'	12' 10"	18' 11-1/4"	10"
		FG-1-15-20	15'	15' 10"	18' 10-1/4"	10"
25'	FG-1-10-25	10'	11' 0"	23' 9-1/4"	12"	
	FG-1-12-25	12'	13' 0"	23' 9-1/4"	12"	
	FG-1-15-25	15'	16' 0"	23' 8-1/4"	12"	
2 TON	8'	FG-2-10-8	10'	10' 8"	6' 10-1/4"	8"
		FG-2-12-8	12'	12' 8"	6' 10-1/4"	8"
		FG-2-15-8	15'	15' 8"	6' 9-1/4"	8"
	10'	FG-2-10-10	10'	10' 8"	8' 10-1/4"	8"
		FG-2-12-10	12'	12' 8"	8' 10-1/4"	8"
		FG-2-15-10	15'	15' 8"	8' 9-1/4"	8"
	12'	FG-2-10-12	10'	10' 8"	10' 10-1/4"	8"
		FG-2-12-12	12'	12' 8"	10' 10-1/4"	8"
		FG-2-15-12	15'	15' 8"	10' 9-1/4"	8"
	15'	FG-2-10-15	10'	10' 10"	13' 10-1/4"	10"
		FG-2-12-15	12'	12' 10"	13' 10-1/4"	10"
		FG-2-15-15	15'	15' 10"	13' 9-1/4"	10"
	20'	FG-2-10-20	10'	11' 0"	18' 8-1/4"	12"
		FG-2-12-20	12'	13' 0"	18' 8-1/4"	12"
		FG-2-15-20	15'	16' 0"	18' 7-1/4"	12"
25'	FG-2-10-25	10'	11' 3"	23' 8-1/4"	16"	
	FG-2-12-25	12'	13' 3"	23' 8-1/4"	16"	
	FG-2-15-25	15'	16' 3"	23' 7-1/4"	16"	
3 TON	8'	FG-3-10-8	10'	10' 10"	6' 7-1/4"	10"
		FG-3-12-8	12'	12' 10"	6' 7-1/4"	10"
		FG-3-15-8	15'	15' 10"	6' 7-1/4"	10"
	10'	FG-3-10-10	10'	10' 10"	8' 7-1/4"	10"
		FG-3-12-10	12'	12' 10"	8' 7-1/4"	10"
		FG-3-15-10	15'	15' 10"	8' 7-1/4"	10"
	12'	FG-3-10-12	10'	10' 10"	10' 7-1/4"	10"
		FG-3-12-12	12'	12' 10"	10' 7-1/4"	10"
		FG-3-15-12	15'	15' 10"	10' 7-1/4"	10"
	15'	FG-3-10-15	10'	11' 0"	13' 7-1/4"	12"
		FG-3-12-15	12'	13' 0"	13' 7-1/4"	12"
		FG-3-15-15	15'	16' 0"	13' 7-1/4"	12"
	20'	FG-3-10-20	10'	11' 3"	18' 7-1/4"	16"
		FG-3-12-20	12'	13' 3"	18' 7-1/4"	16"
		FG-3-15-20	15'	16' 3"	18' 7-1/4"	16"
25'	FG-3-10-25	10'	11' 6"	23' 6"	18"	
	FG-3-12-25	12'	13' 6"	23' 6"	18"	
	FG-3-15-25	15'	16' 6"	23' 6"	18"	

All Gantry Cranes shown above, the Tread (E) dimension is 78" between caster pivot centers. Polyurethane 6" diameter steel casters are standard.

#### Model Number Explanation:

Example: FG-1-12-8; FG = Fixed Gantry Crane, 1 = 1 Ton (2,000 pound) capacity, 12 = Height Under Beam (B) in feet, 8 = Overall Span (A) in feet. Specifications subject to change without notice. Available in capacities to 5 ton and spans to 30 feet. Special capacities, heights, casters and spans are available. Price on request.

## THE MOBILE SOLUTION

Gorbel's Fixed Height Steel Gantry Cranes provide an economical way to lift materials anywhere in a facility. Gorbel's heavy duty end frame design with square tubing uprights, knee braces and channel base provides stable lifting and movement.

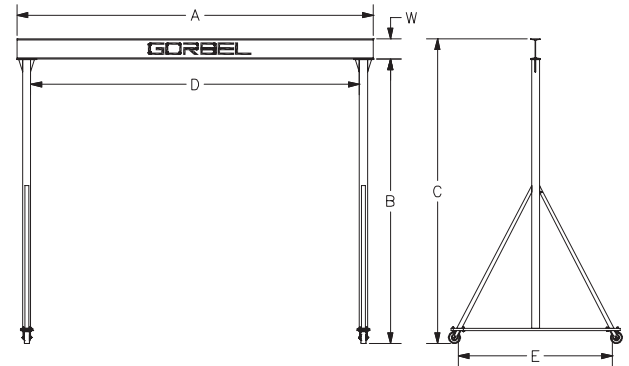

## GORBEL'S ADVANTAGE

### EASE OF MOVEMENT

- The non-marking, durable polyurethane casters provide low rolling resistance for easy movement. The polyurethane wheel rolls smoothly, even over rough floor surfaces, and can withstand water, oil and most other chemicals.

### SAFETY

- Bolted beam to upright connection to ensure that beam does not dislodge.
- Pre-engineered for use with powered hoists. A factor of 15% of the crane capacity is allowed for the hoist and trolley weight with an additional 25% of the capacity allowed for impact, thus giving maximum capacity use of the crane.



# ADJUSTABLE STEEL GANTRY CRANES

## THE FLEXIBLE SOLUTION

Gorbel's Adjustable Steel Gantry Crane provides the most flexible lifting solution of any style jib crane. The Adjustable Gantry can be moved to almost any location and can be easily adjusted to provide different lifting heights.

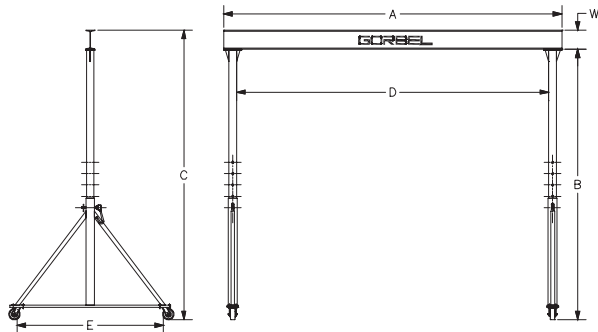

## EASE OF INSTALLATION

- All bolted connections between the beam and uprights.

## OPTIONS

- Four position swivel locking casters.
- V-groove casters for track mounted cranes.
- Steel casters.
- Casters with wheel brakes.
- V-groove track.

CAPACITY	A SPAN	MODEL NUMBER	B HUB MIN/MAX	C OAH MIN/MAX	D CLEAR SPAN	W I-BEAM DEPTH
1 TON	8'	AG-1-7/10-8	7' to 10'	7' 6" to 10' 6"	6' 10-5/8"	6"
		AG-1-10/12-8	10' to 12'	10' 6" to 12' 6"	6' 10-5/8"	6"
		AG-1-12/15-8	12' to 15'	12' 6" to 15' 6"	6' 9-5/8"	6"
	10'	AG-1-7/10-10	7' to 10'	7' 6" to 10' 6"	8' 10-5/8"	6"
		AG-1-10/12-10	10' to 12'	10' 6" to 12' 6"	8' 10-5/8"	6"
		AG-1-12/15-10	12' to 15'	12' 6" to 15' 6"	8' 9-5/8"	6"
	12'	AG-1-7/10-12	7' to 10'	7' 6" to 10' 6"	10' 10-5/8"	6"
		AG-1-10/12-12	10' to 12'	10' 6" to 12' 6"	10' 10-5/8"	6"
		AG-1-12/15-12	12' to 15'	12' 6" to 15' 6"	10' 9-5/8"	6"
	15'	AG-1-7/10-15	7' to 10'	7' 7" to 10' 7"	13' 10-5/8"	7"
		AG-1-10/12-15	10' to 12'	10' 7" to 12' 7"	13' 10-5/8"	7"
		AG-1-12/15-15	12' to 15'	12' 7" to 15' 7"	13' 9-5/8"	7"
20'	AG-1-7/10-20	7' to 10'	7' 10" to 10' 10"	18' 10-5/8"	10"	
	AG-1-10/12-20	10' to 12'	10' 10" to 12' 10"	18' 10-5/8"	10"	
	AG-1-12/15-20	12' to 15'	12' 10" to 15' 10"	18' 9-5/8"	10"	
25'	AG-1-7/10-25	7' to 10'	8' 0" to 11' 0"	23' 8-5/8"	12"	
	AG-1-10/12-25	10' to 12'	11' 0" to 13' 0"	23' 8-5/8"	12"	
	AG-1-12/15-25	12' to 15'	13' 0" to 16' 0"	23' 7-5/8"	12"	
2 TON	8'	AG-2-7/10-8	7' to 10'	7' 8" to 10' 8"	6' 9-5/8"	8"
		AG-2-10/12-8	10' to 12'	10' 8" to 12' 8"	6' 9-5/8"	8"
		AG-2-12/15-8	12' to 15'	12' 8" to 15' 8"	6' 8-5/8"	8"
	10'	AG-2-7/10-10	7' to 10'	7' 8" to 10' 8"	8' 9-5/8"	8"
		AG-2-10/12-10	10' to 12'	10' 8" to 12' 8"	8' 9-5/8"	8"
		AG-2-12/15-10	12' to 15'	12' 8" to 15' 8"	8' 8-5/8"	8"
	12'	AG-2-7/10-12	7' to 10'	7' 8" to 10' 8"	10' 9-5/8"	8"
		AG-2-10/12-12	10' to 12'	10' 8" to 12' 8"	10' 9-5/8"	8"
		AG-2-12/15-12	12' to 15'	12' 8" to 15' 8"	10' 8-5/8"	8"
	15'	AG-2-7/10-15	7' to 10'	7' 10" to 10' 10"	13' 9-5/8"	10"
		AG-2-10/12-15	10' to 12'	10' 10" to 12' 10"	13' 9-5/8"	10"
		AG-2-12/15-15	12' to 15'	12' 10" to 15' 10"	13' 8-5/8"	10"
20'	AG-2-7/10-20	7' to 10'	8' 0" to 11' 0"	18' 7-5/8"	12"	
	AG-2-10/12-20	10' to 12'	11' 0" to 13' 0"	18' 7-5/8"	12"	
	AG-2-12/15-20	12' to 15'	13' 0" to 16' 0"	18' 6-5/8"	12"	
25'	AG-2-7/10-25	7' to 10'	8' 3" to 11' 3"	23' 7-5/8"	16"	
	AG-2-10/12-25	10' to 12'	11' 3" to 13' 3"	23' 7-5/8"	16"	
	AG-2-12/15-25	12' to 15'	13' 3" to 16' 3"	23' 6-5/8"	16"	
3 TON	8'	AG-3-7/10-8	7' to 10'	7' 10" to 10' 10"	6' 6-5/8"	10"
		AG-3-10/12-8	10' to 12'	10' 10" to 12' 10"	6' 6-5/8"	10"
		AG-3-12/15-8	12' to 15'	12' 10" to 15' 10"	6' 6-1/2"	10"
	10'	AG-3-7/10-10	7' to 10'	7' 10" to 10' 10"	8' 6-5/8"	10"
		AG-3-10/12-10	10' to 12'	10' 10" to 12' 10"	8' 6-5/8"	10"
		AG-3-12/15-10	12' to 15'	12' 10" to 15' 10"	8' 6-1/2"	10"
	12'	AG-3-7/10-12	7' to 10'	7' 10" to 10' 10"	10' 6-5/8"	10"
		AG-3-10/12-12	10' to 12'	10' 10" to 12' 10"	10' 6-5/8"	10"
		AG-3-12/15-12	12' to 15'	12' 10" to 15' 10"	10' 6-1/2"	10"
	15'	AG-3-7/10-15	7' to 10'	8' 0" to 11' 0"	13' 6-5/8"	12"
		AG-3-10/12-15	10' to 12'	11' 0" to 13' 0"	13' 6-5/8"	12"
		AG-3-12/15-15	12' to 15'	13' 0" to 16' 0"	13' 6-1/2"	12"
20'	AG-3-7/10-20	7' to 10'	8' 3" to 11' 3"	18' 6-5/8"	16"	
	AG-3-10/12-20	10' to 12'	11' 3" to 13' 3"	18' 6-5/8"	16"	
	AG-3-12/15-20	12' to 15'	13' 3" to 16' 3"	18' 6-1/2"	16"	
25'	AG-3-7/10-25	7' to 10'	8' 6" to 11' 6"	23' 5-3/8"	18"	
	AG-3-10/12-25	10' to 12'	11' 6" to 13' 6"	23' 5-3/8"	18"	
	AG-3-12/15-25	12' to 15'	13' 6" to 16' 6"	23' 5-1/4"	18"	

All Gantry Cranes shown above, the Tread (E) dimension is 78" between caster pivot centers. Polyurethane 6" diameter steel casters are standard.

### Model Number Explanation:

Example: AG-1-12/15-20; AG = Adjustable Gantry Crane, 1 = 1 Ton (2,000 pound) capacity, 12/15 = min / max Height Under Beam (B) in feet, 20 = Overall Span (A) in feet. Specifications subject to change without notice. Available in capacities to 5 ton and spans to 30 feet. Special capacities, heights, casters and spans are available. Price on request.



### FOR MORE INFORMATION

Your authorized Gorbel dealer can give you more information on what makes Gorbel's Ergonomic Work Station Cranes and other material handling products "A Class Above."

### BRIDGE CRANES



FREE STANDING



CEILING MOUNTED

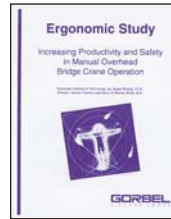

ERGONOMIC STUDY

### ERGONOMIC LIFTING



G-FORCE™



EASY ARM™

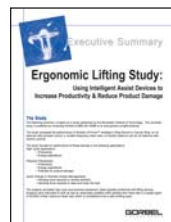

ERGONOMIC STUDY

### JIB CRANES



JIB CRANES

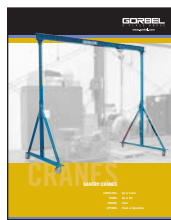

GANTRY CRANES



WORK STATION JIBS



ARTICULATING JIBS

### SPECIALTY PRODUCTS



SEISMIC ZONE IV



TELESCOPING

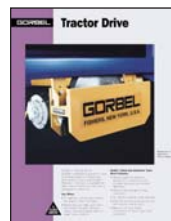

TRACTOR DRIVES



INTERLOCK/TRANSFER

**GORBEL**  
A CLASS ABOVE

[www.gorbel.com](http://www.gorbel.com)

GORBEL  
600 Fishers Run  
PO Box 593  
Fishers, NY 14453 USA

T 800.821.0086  
T 585.924.6262  
F 585.924.6273  
E [info@gorbel.com](mailto:info@gorbel.com)

CRANES